

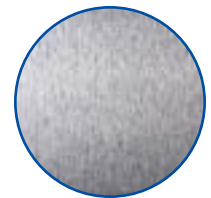

MGQ Finish Line Spray Gun

MGQ Finish Line Spray Gun

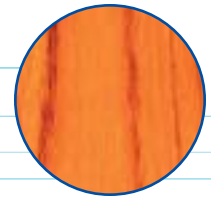
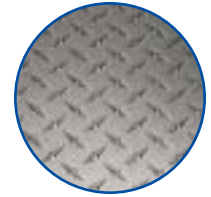

Because the Finish is Everything!

A Versatile and Affordable Spray Gun – Built Right, From The Start

The FinishLine MGQ model spray gun is for the painter looking for versatility in a spray gun which will apply a variety of materials with good results. Designed and manufactured by the leader in spray technology, the MGQ spray gun offers affordability and quality, all backed by a written warranty and spare parts availability.

MGQ – “Value Packaged”

Compare MGQ’s features with other guns in its class and you’ll see the difference! The MGQ is a complete spraying outfit, with the ability to tackle materials from very low viscosity lacquers and enamels to very high viscosity protective coatings. In fact, it’s because of its pressure feed design that the MGQ works extremely well in delivering these heavy materials to the front of the gun for atomization.

Dual Air Caps

With the MGQ spray gun you have the choice of using an internal mix or external mix air cap (see below), which are both included in the gun package. With either air cap, the MGQ will provide very good spray finishing results.

- External Mix Air Cap is excellent for spraying heavy materials where finer atomization isn’t required. Use this cap for spraying materials such as primers, fillers, sealers, liquid mask, protective, maintenance, and light viscosity multi-color coatings
- Internal Mix Air Cap is recommended for spraying light to medium viscosity materials, which require finer atomization

MGQ Finish Line Spray Gun

Extensive Applications

From industrial maintenance applications to woodworking around the home or farm, the MGQ is designed to do it all, and works well with air compressors as small as 3/4 hp!

The MGQ spray gun is compatible with many finishing materials, including:

- Primers, Sealers, Fillers
- Engine Paints
- Liquid Mask Materials
- Straight Enamels
- Chip Guards
- Adhesives
- Multi-Color Coatings (touch-up)
- Anti-Rust Coatings
- Chassis Black Coatings
- Maintenance Coatings
- Stains
- Marine Finishes
- Lacquers

Technical Specifications

Air Inlet Threads:	1/4" NPS(M)
Air Consumption:	3.2 cfm @ 40 psi 2.6 cfm @ 30 psi 2.0 cfm @ 20 psi Maximum air inlet pressure is 40 psi



MGQ Finish Line Spray Gun

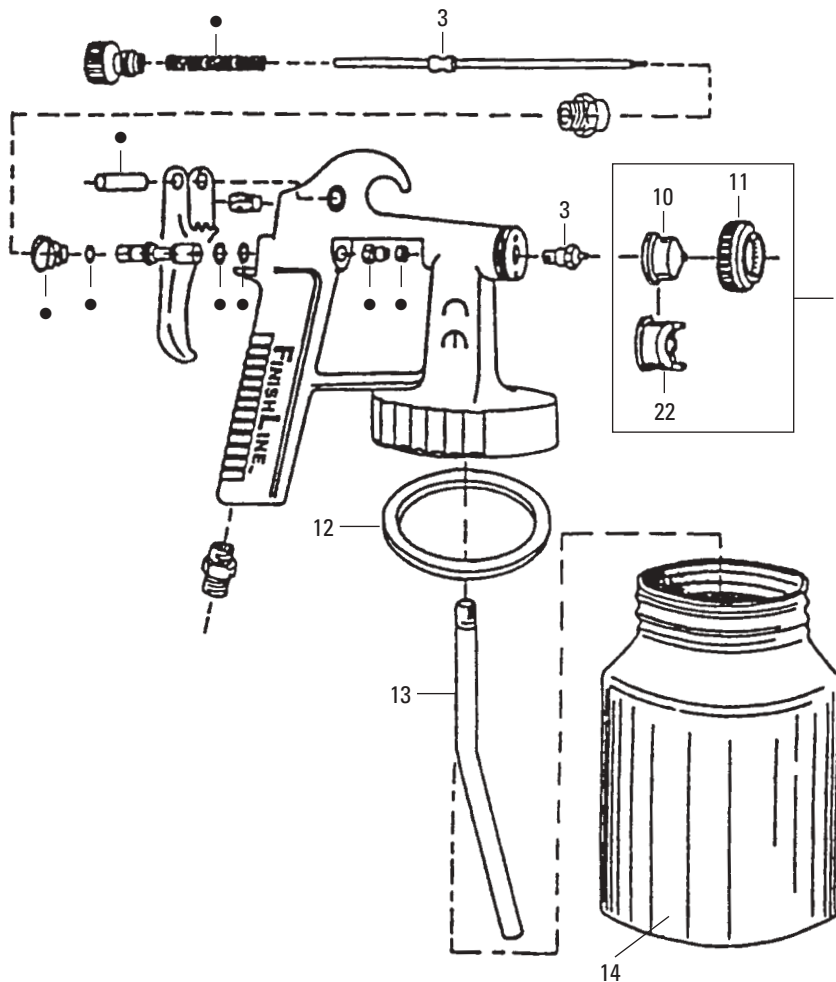

Customer Service 1.800.992.4657

Ref. No.	Model No.	Description	Ind. Parts Required
3	FLG-NS-30669	Flid. Tip and Needle Assy.	1
• 10	FLG-MGQ-30698	Internal Mix Air Cap (includes #'s 11 and 22)	1
11	FLG-MGQ-30698	Retaining Ring (included with #'s 10 and 22)	1
12	FLG-KL-26-K3	Thiokol Gasket	1
14	FLG-GB-34	Metal Cup	1
22	FLG-MGQ-30698	External Mix Air Cap (included with #'s 10 and 11)	1

*These parts are included in Spray Gun Repair Kit No. FLG-NS-30697

FinishLine MGQ Spray Gun Ordering Information

Part No.	Description	Fluid Tip Size	Air Cap Type*	Pattern Length
FLG-MGQ-700-FL	MGQ Pressure Feed Gun and Cup Outfit	1.4 mm	Internal	7"-8"
			External	6"-7"

*Note: Both air caps included with MGQ spray gun outfit.

FinishLine MGQ Spray Gun Accessories

Model No.	Description
FLG-NS-30697 •	MGQ Gun/Cup Repair Kit
FLG-NS-30669	Fluid Tip/Needle Kit (1.4)
FLG-MGQ-30698 ♦	Dual Air Cap/Ring Kit
FLG-KL-26-K3	MGQ Cup Gasket Kit (3)
FLG-GB-34	MGQ Cup Bottom (only)
56-771	Multi-Color Air Nozzle*
56-772	Multi-Color Fluid Nozzle*
FLG-8-K2	Trigger Stud Kit

*Note: The MGQ is ideal for spraying multi-color type coatings, when used with the 56-771 and 56-772 air and fluid nozzles (order separately)



World Headquarters
Industrial Finishing
DeVilbiss
195 Internationale Blvd.
Glendale Heights, IL 60139
630-237-5000
Fax 630-237-5011
www.devilbiss.com

